

Vibration Sensor Type 673



Standard

Instruction Manual

English

Instruction Manual

Vibration Sensor Type 673

Standard

Edition: 10.06.10

Attention!

Before Start-Up Procedure the Instruction Manual must be read and understood!

Should any question arise, please contact:

HAUBER-Elektronik GmbH
Fabrikstraße 6
D-72622 Nürtingen
Germany
Phone: +49 (0) 7022 / 62393
Fax: +49 (0) 7022 / 64143
info@hauber-elektronik.de
www.hauber-elektronik.de

Contents

1 Safety Informations.....	4
2 Instruction Manual Scope	5
3 The Vibration Sensor Type 673 Standard	5
4 Intended Use	5
5 Documents and Certificates	5
6 Application Fields	5
7 Delivery Contents	5
8 Electrical Data	6
9 Mechanical Data	7
10 Connections.....	8
11 Mounting and Demounting	9
12 Installation and Start-Up	10
13 Maintenance and Repairs.....	10

1 Safety Instructions

In General

The safety instructions serve the protection of persons and things from damage and danger that arise from not intended use and further misuse of products especially in explosion endangered areas. Therefore read the instruction manual carefully, before working with or starting-up the product. To the operating personnel the instruction manual has to be accessible anytime.

Before the starting-up or miscellaneous works with the product please check, whether all the documents are available completely. If not all the documents are committed completely or further copies are required, they can be obtained in different languages.

Our product is designed to the latest state of the art. Nevertheless there are a number of residual risks. This means that each person in the operators firm, concerned with mounting and dismounting, installation, start-up, operating or maintenance of the product, has to have read and understood the instruction manual.

This means furthermore that each person in the operators firm, concerned with mounting and dismounting, installation, start-up, operating or maintenance of the product, has to be an authorized expert, familiar with the safety instructions for handling electrical components. For handling ATEX-certified products within explosion endangered surroundings the expert in addition has to be familiar with the safety instructions relevant there.

Used Symbols



This symbol indicates an explosion hazard.



This symbol indicates a risk from electrical current.



This symbol indicates a (non-safety relevant) information.

2 Instruction Manual Scope

The present instruction manual of the Vibration Sensor Type 673 is applicable for the following variants: Standard

3 The Vibration Sensor Type 673 Standard

The Vibration Sensor Type 673 Standard (below listed as Type 673) is applied for measurement of machines absolute bearing vibration, referring to DIN ISO 10816. It works according to the Two-Wire-System. The Measurement parameter is the root mean square (rms) of the vibration velocity, the unit is mm/s. The Sensor delivers an interference-free 4...20 mA output-signal, proportional to the sensors measuring-range. The sensor is supplied with a measuring range according to customers request.

4 Intended Use

The Type 673 exclusively serves for the measurement of mechanical vibrations of machines and mechanical facilities. The operation is valid exclusively within the specifications mentioned in this manual. **Main areas of application:** Industrial fans, ventilators, blowers, electric motors, pumps, centrifuges, seperators, generators, turbines, and similar, oscillatory mechanical equipment.

5 Documents and Certificates

Subsequent Type 673 Document can be consulted and downloaded on www.hauber-elektronik.de:

- EC-Conformity-Declaration

6 Application Fields

Variant	Application Fields
Standard	None explosion endangered areas

7 Delivery Contents

Variant	Delivery Contents
Standard	<ul style="list-style-type: none"> • Vibration Sensor Type 673 • Instruction Manual • Fastening Material (2 x screws, M4 x 25 mm, 2 x nuts, self-locking, 2 x washers)

8 Electrical Data



Before Starting-Up the Sensor, the mains must be secured with a microfuse (time delay, 32 mA, breaking capacity C)!

Measuring Range:

0... 8 mm/s
 0... 16 mm/s
 0... 32 mm/s
 0... 64 mm/s
 0... 128 mm/s
 0... 256 mm/s
 0... 512 mm/s
 0... 1000 mm/s



Each Sensor has **one** of the listed measuring ranges. Further ones on request.

Measurement parameter:

Vibration velocity

Measuring accuracy:

± 5%

Frequency range:

1 Hz...1000 Hz

Output signal:

4...20 mA (Proportional to the Measuring Range)

Voltage supply:

24V DC ± 10%

Power input (max.):

25 mA

Shock (max.):

1000 g

Burden/Load:

500 Ω

Fusing:

Microfuse (Time delay, 32 mA, breaking capacity C)

Operating temperature range:

-30...+80 °C

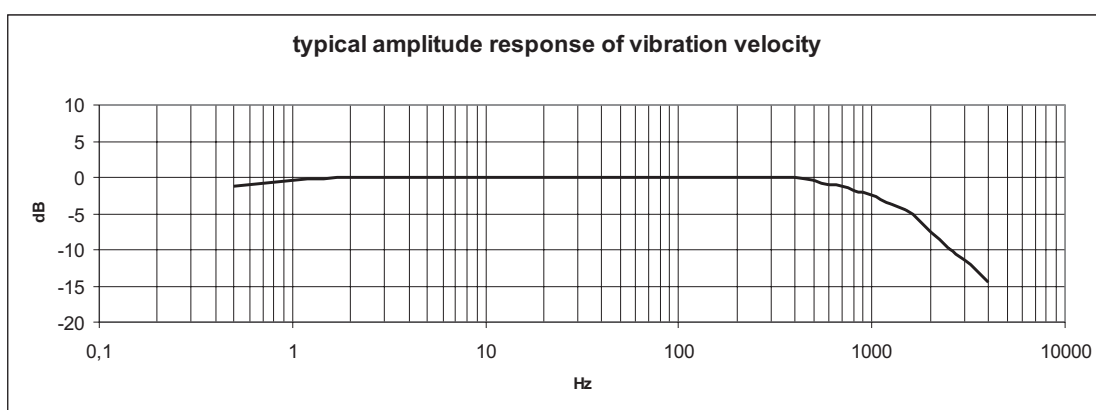

Fig. 1: Frequency Range 1 Hz...1000 Hz

9 Mechanical Data

Housing Material:

Glass fibre reinforced polyester, halogen-free, metal-shielded inside, UV resistant

Cover screw connection:

4 x screws, undetachable

Gasket material:

Chloropren CR, UV resistant

Cable gland:

M12 x 1,5, Polyamid

Cable diameter:

3,5 mm...7 mm

Terminal block:

Max. rated cross section:

Single wire (solid) 4 mm²

Stranded wire (flexible) 2,5 mm²

Stranded wire with ferrules 2,5 mm²

Mounting material:

2 x screws, M4 x 25 mm, diagonal

Mounting:

The Sensor cable must be shielded!
Connect cable shield to pin 4 and to GND / ground at the other end.

Weight:

ca. 500 g

Protection Style:

IP 66

Housing Dimensions and Direction of Measurement

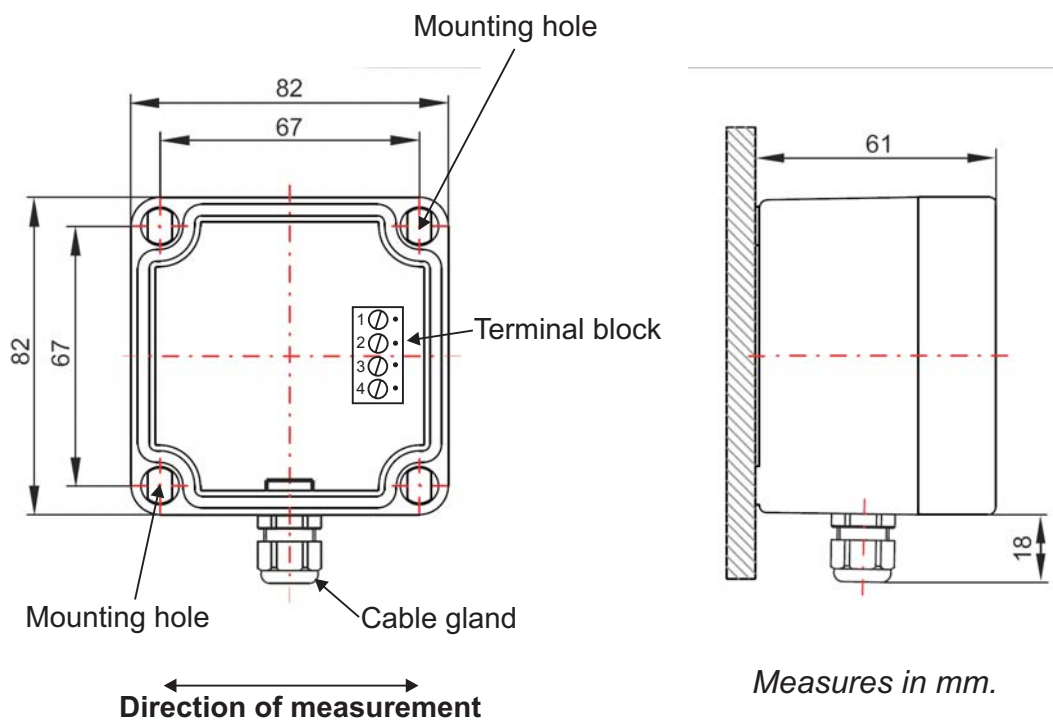

If possible, mount the sensor with the cable gland upside down!

10 Connections

Connection Plan

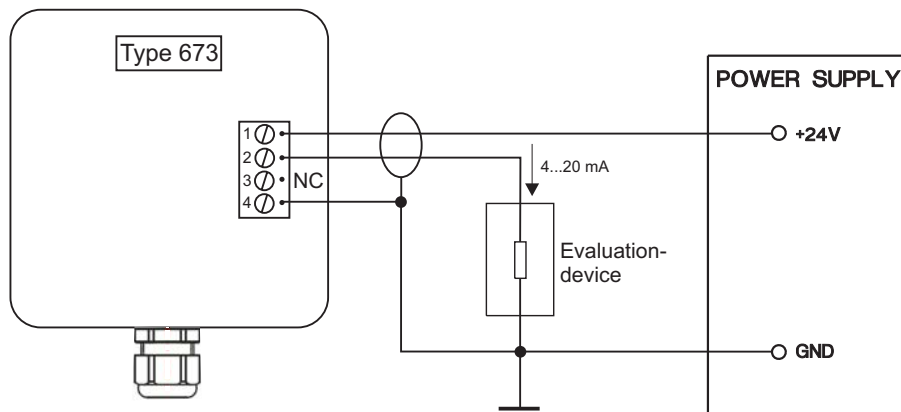

NC = not connected

Pin Allocation

- Pin 1: +24V DC
- Pin 2: 4...20 mA
- Pin 3: NC
- Pin 4: Cable shield



To avoid capacitive interferences, Pin 3 may not be connected (NC)!

11 Mounting and Dismounting

Mounting and Dismounting works at and with the Sensor may only be executed by an authorized expert, familiar with the safety instructions for handling electrical components. For handling ATEX-certified Sensors within explosion endangered surroundings the expert in addition has to be familiar with the safety instructions relevant there.



Before mounting and dismounting works the Sensor has to be separated from the mains! Separated plug and socket devices always have to be disconnected from the mains! Otherwise danger of explosion because of sparking, when operating ATEX-certified Sensors in explosion endangered areas!



The Sensor housing must be earthed via the cable shield of the connection cable!

Fastening at the Mounting Surface

Preconditions

- Mounting surface clean and flat, i.e. free from paint, rust, etc.
- 2 threaded holes at the mounting surface or 2 through-holes at the mounting wall:
Depth (min.): 12 mm
Thread: M4

Tools and Materials

- Screwdriver
- Hexagonal key, SW 3
- Fastening material

Working Steps and hints

- Open cover screws with the screwdriver and remove cover.
- Tighten sensor **friction-locked** by means of the fastening material.



To obtain exact measuring values, the Sensor has to be tighten **friction-locked** at the mounting surface!

Avoid auxiliary constructions! If unavoidable, implement it as stiff as possible!

If possible, mount the sensor with the cable gland upside down! So ingress of moisture can be avoided.

12 Installation and Start-Up

Installing and starting-up the Sensor may only be executed by an authorized expert, familiar with the safety instructions for handling electrical components. For handling ATEX-certified Sensors within explosion endangered surroundings the expert in addition has to be familiar with the safety instructions relevant there.



Prior to starting-up the Sensor, the mains must be secured with a microfuse (time delay, 32 mA, breaking capacity C)!



The connection cable and possible extension cables must be protected against electrical influenzen and mechanical damages. Here local regulations and commissions absolutely have to be considered.

13 Maintenance and Repair

Repairing the Sensor may only be executed by an authorized expert, familiar with the safety instructions for handling electrical components. For handling ATEX-certified Sensors within explosion endangered surroundings the expert in addition has to be familiar with the safety instructions relevant there.



Prior to repair and cleaning works the Sensor has to be seperated from the mains! Seperated plug and socket devices always have to stay disconnected from the mains! Otherwise danger of explosion because of sparkling, when operating ATEX-certified Sensors in explosion endangered areas!



Defective connection cables immediately have to be replaced! Otherwise danger of explosion because of sparkling, when operating ATEX-certified Sensors in explosion endangered areas!

A defective control has to be changed completely!



Note: The Type 673 and ist variants are maintenance free!

Errortable

Error	Cause	Activity
No Measured Value (4-20 mA)	No Power Supply	Check Power Supply and/or Connection Cable
	Connection Cable interrupted	Replace Connection Cable
	Fuse defective	Replace Fuse
	Connection wrong Polarity	Provide correct Polarity
	Sensor defektive	Replace Sensor
Measured Value wrong	Sensor mounting not friction-locked	Mount Sensor friction-locked
	Sensor mounted at wrong position	Mount Sensor at correct position