

Vibration Control Type 663 - Window

SIL2

PL - d



Standard



Zone-1-21 



Zone-2-22 

Instruction Manual

English

Instruction Manual

Vibration Control
Typ 663 - Window

Standard
Zone-1-21
Zone-2-22

Edition: 24.03.2011

Attention!

Before Start-Up Procedure the Instruction Manual must be read and understood!

Should any question arise, please contact:

HAUBER-Elektronik GmbH
Fabrikstraße 6
D-72622 Nuertingen
Germany
Phone.: +49 (0) 7022 / 62393
Fax: +49 (0) 7022 / 64143
info@hauber-elektronik.de
www.hauber-elektronik.de

Content

1 Safety Informations.....	4
2 Instruction Manual Scope	5
3 Vibration Control Typ 663 - Window	5
Standard, Zone-1-21, Zone-2-22	
4 Intended Use	5
5 Safety Level.....	5
6 Documents and Certificates	5
7 Application Fields	6
8 Delivery Contents	6
9 Electrical Data	7
10 Mechanical Data.....	8
11 Connections.....	9
12 Functional Description	10
13 Limit Value Adjustment.....	11
14 Self Check	11
15 Mounting and Demounting	12
15.1 Fastening at the Mounting Surface	12
15.2 Zone-2-22 - Fastening Safety Clip / Protective Cover	13
16 Installation and Start-Up	14
17 Maintenance and Repairs.....	14
18 Responsibility for the Safe Operation / Disclaimer	15

1 Safety Instructions

In General

The safety instructions serve the protection of persons and things from damage and danger that arise from not intended use and further misuse of products especially in explosion endangered areas. Therefore read the instruction manual carefully, before working with or starting-up the product. To the operating personnel the instruction manual has to be accessible anytime.

Before the starting-up or miscellaneous works with the product please check, whether all the documents are available completely. If not all the documents are committed completely or further copies are required, they can be obtained in different languages.

Our product is designed to the latest state of the art. Nevertheless there are a number of residual risks. This means that each person in the operators firm, concerned with mounting and dismounting, installation, start-up, operating or maintenance of the product, has to have read and understood the instruction manual.

This means furthermore that each person in the operators firm, concerned with mounting and dismounting, installation, start-up, operating or maintenance of the product, has to be an authorized expert, familiar with the safety instructions for handling electrical components. For handling ATEX-certified products within explosion endangered surroundings the expert in addition has to be familiar with the safety instructions relevant there.

Used Symbols



This symbol indicates an explosion hazard.



This symbol indicates a risk from electrical current.



This symbol indicates a (non-safety relevant) information.

2 Instruction Manual Scope

The present instruction manual of the Vibration Control Type 663 - Window is applicable for the variants: Standard, Zone-1-21 and Zone-2-22.

The functionality of the variants is identical. In addition the variants have certifications and labellings, that allow operation in explosion endangered areas. (see chap. 7, Application Fields)

3 Vibration Control Typ 663

The Vibration Control Typ 663 - Window ist applied for measurement and control of machines vibration-acceleration. Measurement parameter is the root mean square (rms) of the vibration. The signal evaluation takes place via two built-in relays and one analogue output of 4...20 mA, proportionally to the measured window. The relay outputs have a window-control. Within the window-range the acceleration-value intermediates two adjustable limit values and both relays are energized. If the acceleration value exceeds the limit-values of the window-range, the respective relay drops down.

4 Intended Use

The Type 663 - Window serves as protection for machines and mechanical equipment against undue mechanical vibrations. It exclusively serves for measurement of mechanical vibrations. Main areas of application: Conveyor and sieving equipment, drying and cooling systems and similar oscillating mechanical plants and equipment.

5 Safety Level

The Type 663 - Window is tagged by subsequent safety levels:

SIL2 - Safety Integrity Level, SIL2 / FMEDA, nach IEC 61508









PL-d - Performance Level, PL-d, nach DIN ISO 13849

6 Documents and Certificates

Subsequent Type 663 - Window Documents und Certifikates can be consulted on www.hauber-elektronik.de:

- EC-Conformity-Declaration
- Certificate - Safety Integrity Level, SIL2 / FMEDA
- Certificate - Performance Level, PL-d
- EC-Type-Examination-Certificate ATEX-Zone 1 und 21, no.: SNCH 09 ATEX 4380
- Statement-of-Conformity ATEX-Zone 2 und 22, no.: LU 09 ATEX 0065X

7 Application Fields

Variant	Application Fields	Labelling
Standard	None explosion endangered Areas	 
Zone-1-21	Explosion endangered Areas Zone 1 und 21	  II 2G Ex d IIC T4  II 2D Ex tD A21 IP65 T120 °C
Zone-2-22	Explosion endangered Areas Zone 2 und 22	  II 3G Ex nC II T4  II 3D Ex tD A22 IP55 T125 °C

8 Delivery Contents

Variant	Delivery Contents
Standard	<ul style="list-style-type: none"> • Vibration Control Typ 663 - Windows • Cylinder Bolt, M8 x 20 mm • Spring Ring, M8 • Instruction Manual
Zone-1-21	<ul style="list-style-type: none"> • Vibration Control Typ 663 - Windows, with infused Cable, L= 2 m, 5 m oder 10 m, • Cylinder Bolt, M8 x 20 mm • Spring Ring, M8 • Instruction Manual
Zone-2-22	<ul style="list-style-type: none"> • Vibration Control Typ 663 - Windows • Protective Cover for M12-Plug • Safety Clip • Cylinder Bolt, M8 x 20 mm • Spring Ring, M8 • Instruction Manual
Available Supplies	<ul style="list-style-type: none"> • Allocable Mating Connector, M12, 8-pole • Connection Cable, M12-Socket, 8-pole, 0,25 mm², L= 2 m, 5 m oder 10 m

9 Electrical Data



The housing cover may only be unscrewed, if the Control is either separated from the mains or no explosion endangered atmosphere exists. Otherwise danger of explosion because of sparking, when the ATEX-certified Control is operating in explosion endangered areas!

Before Starting-Up the Control, the mains must be secured with a microfuse (time delay, 160 mA, breaking capacity C)!

Measuring range:

0...4 g (Peak)
0...12 g (Peak)



Note: Each Type 663 has one of the listed measuring ranges. Further ones on request.

Measuring accuracy:

± 5%

Frequency range:

10 Hz...1000 Hz (Standard)
1 Hz...1000 Hz (optionally)

Output signals:

1 x 4...20 mA
2 x Relay contact (Pre- and Mainalarm)

Relay switching duty:

1A / 30V DC

Voltage supply:

24V DC ± 10%

Power input (max.):

80 mA

Shock (max.):

1000 g

Surroundings temperatur:

-20°C...+60°C

Operating temperatur range:

-20°C...+85°C (Meas.-head-temp. a.t. fastening)

Burden/load:

500 Ω

Fusing:

Microfuse (time delay, 160 mA, breaking capacity C)

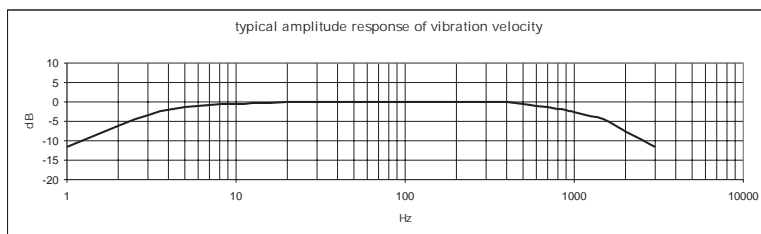

Fig. 1: Frequency range 10 Hz...1000 Hz

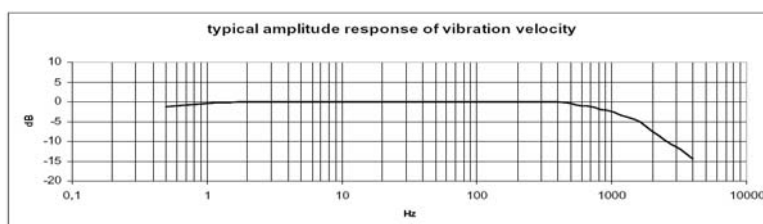

Fig. 2: Frequency range 1 Hz...1000 Hz

10 Mechanical Data

Housing Material:

M12-connector material:

Fastening:

Securing:

Weight:

Protection Style:

Stainless Steel V2A; material no: 1.4305

CuZn (brass), nickel plated

Inner hexagon screw, M8 x 20 mm

The sensor must be earthed via the M8 fastening (see chapt.15).

ca. 500 g

IP 67

Housing Dimensions and Direction of Measurement

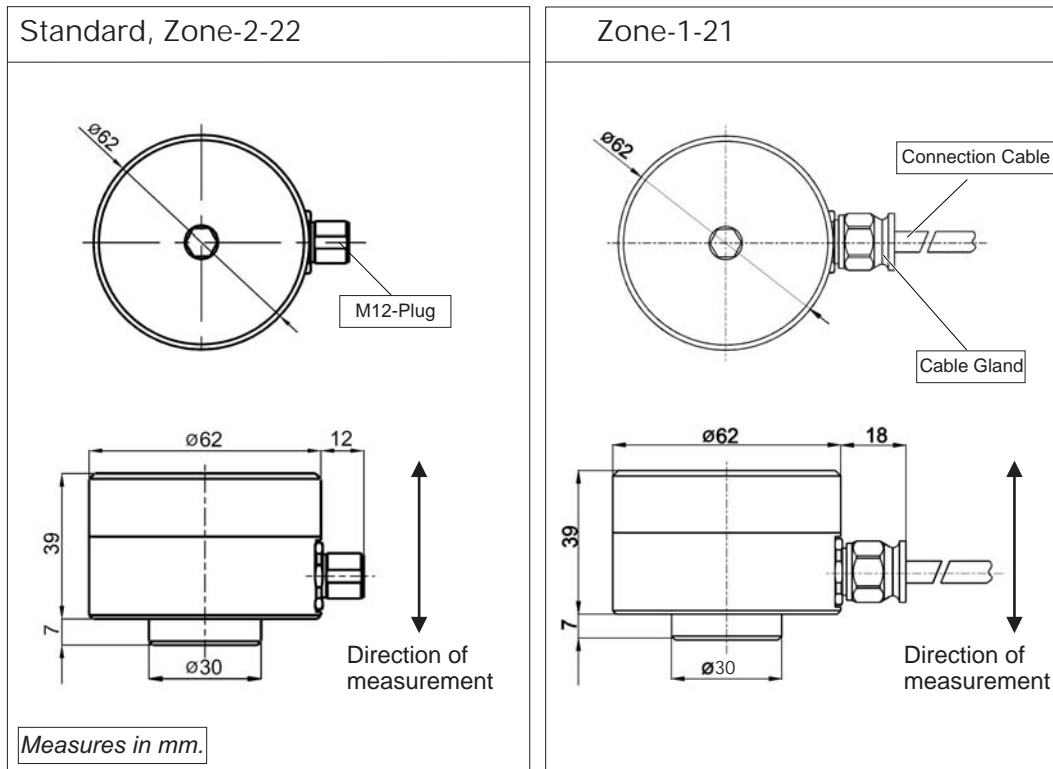

Fig. 3: Housing Dimensions and Direction of Measurement: Standard, Zone-2-22

Fig. 4: Housing Dimensions and Direction of Measurement: Zone-1-21



Note: Direction of Measurement = Direction of Fastening

11 Connections

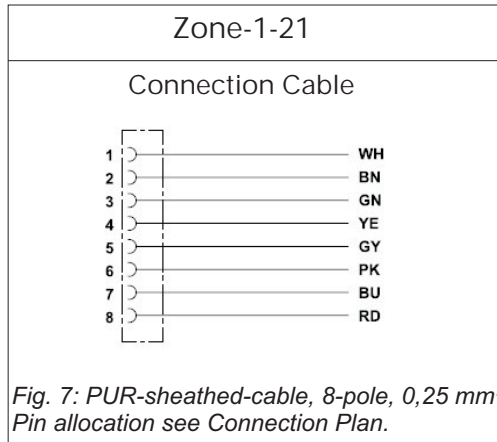
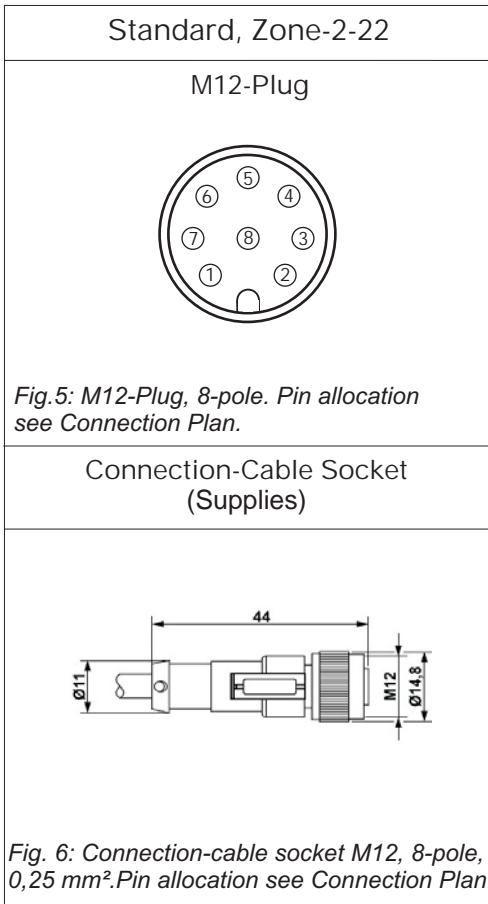

Connection Plan for all 3 Variants

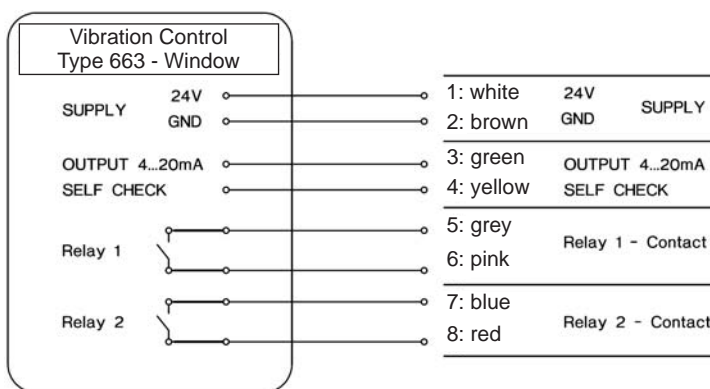

Fig. 8: Connection Plan Type 663 - Window



Info: Displayed in the Connection Plan is the Alarm Condition resp. Currentless Condition!
Relay 1 and Relay 2 are dropped out. (Further informations on operating states, chap. 12)

12 Functional Description

The Type 663 - Window is applied for the detection of vibration-acceleration. If the value of the acceleration is below or above an adjustable window-range, an alarm is generated. The sensor contains two independent channels - LIM1 and LIM2. The lower limit of the window-range will be adjusted with LIM1 and the upper limit with LIM2 (see Fig. 9).

<p>Settings</p> <ul style="list-style-type: none"> • SET Turn-switch : • TIME Potentiometer : 	<p>Adjustment of the limit in 15 steps (see table 3.5).</p> <p>Adjustment of the delay-time, without steps, 0...30 sec.</p>
<p>Operating conditions</p> <ul style="list-style-type: none"> • Green OK-LED: • Yellow WARNING-LED: • Red ALARM-LED: 	<p>The acceleration-value moves within the window-range.</p> <p>The acceleration-value has exceeded the window-range, and the delay-time of the alarm is running.</p> <p>The acceleration-value has exceeded the window-range, and the delay-time of the alarm has expired.</p>

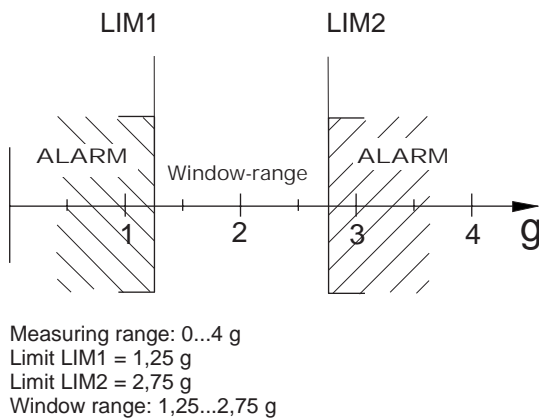

Fig. 9: Example Adjustment Window-range

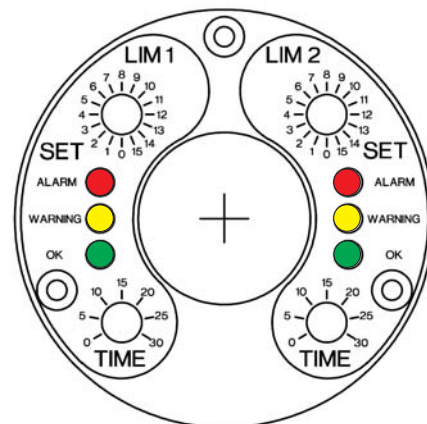

Fig. 10: Operator's controls

15 Mounting and Dismounting

Mounting and Dismounting works at and with the Control may only be executed by an authorized expert, familiar with the safety instructions for handling electrical components. For handling ATEX-certified controls within explosion endangered surroundings the expert in addition has to be familiar with the safety instructions relevant there.



Before mounting and dismounting works the control has to be separated from the mains! Separated plug and socket devices always have to be disconnected from the mains! Otherwise danger of explosion because of sparking, when operating ATEX-certified Types 663 in explosion endangered areas!



The control housing must be earthed via ist fastening - i. e. via machine earth or via a separate earth wire (PE)!

15.1 Fastening at the Mounting Surface

Preconditions

- Mounting surface clean and flat, i.e. free from paint, rust, etc.
- Threaded hole at the Mounting surface:
Depth: 15 mm
Thread: M8

Tools and Materials

- Allen wrench, SW6, SW8
- Torque wrench SW8
- Allen screw M8x20
- Snapping for M8

Working Steps

1. Unscrew housing cover from housing base.
 - Allen wrench, SW8
2. Fasten control friction-locked at the mounting surface by use of allen screw and snap ring.
 - Allen wrench, SW6
3. Tighten housing cover on housing base loosely by hand.
(Do not tilt the thread!)
Tighten housing cover with a tightening torque = 5 Nm.
 - Torque wrench SW8

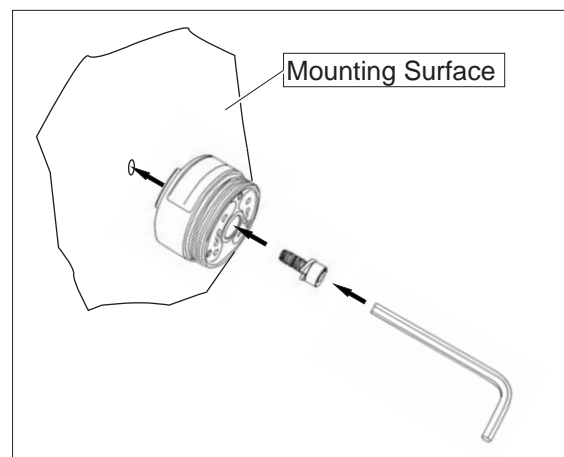

Fig. 11: Fastening at the mounting surface

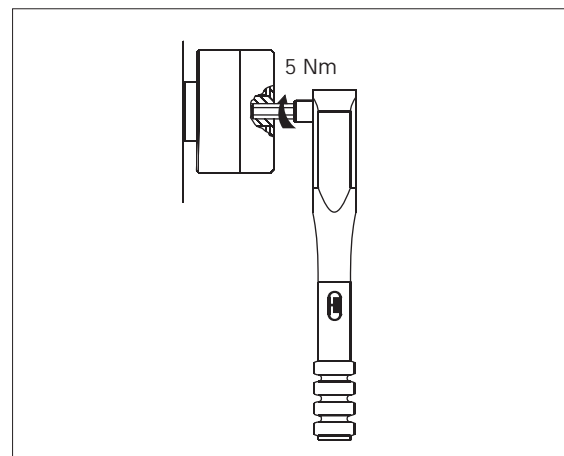

Fig. 12: Tightening housing cover with a torque wrench



Note: To avoid a possible galling of the housing cover with the housing base, it is recommended before the final mounting to treat the housing cover thread with a mounting paste for high-grade steel connections.

15.2 Zone-2-22 - Fastening Safety Clip / Protective Cover



The operation of variant Zone-2-22 is not permitted without the safety clip, to avoid accidentally disconnecting the plug-in connection! Otherwise danger of explosion because of sparking, when operating in explosion endangered areas!

Fastening Safety Clip

1. Plug in the connection cable socket into the M12-plug completely.
(Pay attention to the code cam!).
2. Tighten firmly the lock-nut of the connection cable socket by hand.
3. Fasten the safety clip against accidental disconnection of the plug connection:
 1. Put both shell halves of the safety clip around the plug connection.
 2. Press together by hand both shell halves of the safety clip until the catch lock snaps in.
 3. Put the arrow connected to one shell half around the cable, then stick it through the eye on the other end, so that the notice sign is readable alongside the cable.

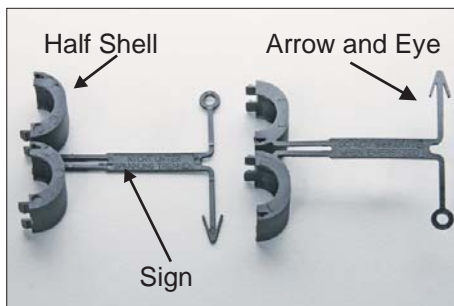

Fig. 13: Safety Clip

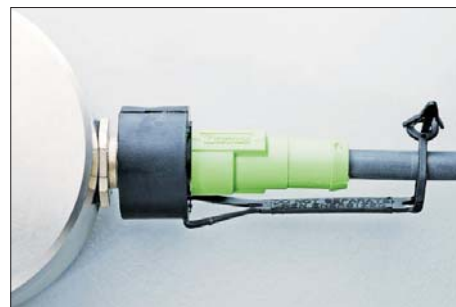

Fig. 14: Fastened Safety Clip

Fastening Protective Cover

After disconnecting the plug connection the protective cover has to be fastened!

Disassemble the safety clip and mount the protective cover:

1. Disconnect mains / electric circuit.
2. Separate both shell halves of the fuse clip with a screw driver.
3. Fasten protective cover and skrew it tightly onto the sensor plug.



Fig. 15: Protective Cover



Fig. 16: Fastened Protective Cover

16 Installation and Start-Up

Installing and starting-up the control may only be executed by an authorized expert, familiar with the safety instructions for handling electrical components. For handling ATEX-certified controls within explosion endangered surroundings the expert in addition has to be familiar with the safety instructions relevant there.



Starting-up may only be executed with correctly tightened housing cover (tightening torque = 5 Nm)! Otherwise danger of explosion because of sparking, when operating ATEX-certified Types 663 in explosion endangered areas!



Prior to starting-up the Type 663, the mains must be secured with a microfuse (time delay, 160 mA, breaking capacity C)!

The connection cable and possible extension cables must be protected against electrical influences and mechanical damages. Here local regulations and commissions absolutely have to be considered.

17 Maintenance and Repairs

Repairing the control may only be executed by an authorized expert, familiar with the safety instructions for handling electrical components. For handling ATEX-certified controls within explosion endangered surroundings the expert in addition has to be familiar with the safety instructions relevant there.



Prior to repair and cleaning works the Type 663 has to be separated from the mains! Separated plug and socket devices always have to stay disconnected from the mains! Otherwise danger of explosion because of sparking, when operating ATEX-certified Types 663 in explosion endangered areas!



Defective connection cables immediately have to be replaced! Otherwise danger of explosion because of sparking, when operating ATEX-certified Types 663 in explosion endangered areas!

A defective control has to be changed completely!



Note: The Type 663 and ist variants are maintenance free!

Errortable

Error	Cause	Activity
No measured value (4-20 mA)	No power supply	Check power supply and/or connection cable
	Connection cable interrupted	Replace connection cable
	Fuse defective	Replace fuse
	Wrong connection cable polarity	Provide correct connection cable polarity
	Control defective	Replace Control
Relay does not switch	Limit Value adjustment wrong	Adjust Limit Value correctly
	No power supply	Check power supply and/or connection cable
	Connection cable interrupted	Replace connection cable
	Fuse defective	Replace fuse
	Polarity of connection cable wrong	Polarize connection cable correctly
Measured value wrong	Control defective	Replace Control
	Control mounting not friction-locked	Mount Control friction-locked
	Control mounting at wrong position	Mount Control at correct position

18 Responsibility for the Safe Operation / Disclaimer

The correct layout of the electrical plant under conditions of explosion protection, as well as the correct switch on procedure, is the sole responsibility of the user of the plant.

The current valid explosion protection rules and security regulations must be adhered to and must be under given circumstances checked by a competent person. Should the plant on the order of the user be erected by a subcontractor, the plant must only be switched on after the subcontractor has submitted an installation certificate as prove of the correct nature of the installation, according to the relevant valid regulations.

The primary switch on of explosion protected plants or part of plants, as well as the subsequent switch on after major adjustments or maintenance work, must be reported to the relevant authorities by the owner.