

Evaluation Devices

Type 656 A / B



Evaluation: Current-signal (4...20 mA)
from Vibration Controls in two-wire
technology. (Typ 640 und 664)

Instruction Manual

Evaluation Devices Type 656 A / B

Edition: 31.10.11

Attention!

Before Start-Up Procedure the Instruction Manual must be read and understood!

Should any question arise, please contact:

HAUBER-Elektronik GmbH
Fabrikstraße 6
D-72622 Nürtingen
Germany
Phone: +49 (0) 7022 / 62393
Fax: +49 (0) 7022 / 64143
info@hauber-elektronik.de
www.hauber-elektronik.de

Instruction Manual Scope

The present instruction manual is applicable for the Evaluation Devices Type 656 A / B.

The Evaluation Device Type 656 A

The Evaluation Device Type 656 A is applied for the current-signal detection and evaluation of vibration controls in two-wire technology. At the Evaluation Device switching-threshold and delay can be set. If the signal is exceeding the switching-threshold and the delay has expired, this will be signalled by means of LED and relay. Cable break and missing voltage supply will also be signalled. At a later stage this signals can be used for the generation of an alarm.

Intended Use Type 656 A

The Evaluation Device Type 656 A exclusively serves for the current-signal detection and evaluation of vibration sensors. The operation is valid exclusively within the specifications mentioned in this manual.

Main areas of application: Vibration measurement on industrial fans, ventilators, blowers, electric motors, pumps, centrifuges, separators, generators, turbines, and similar, oscillatory mechanical equipment, were a specific vibration value must not be exceeded.

The Evaluation Device Type 656 B

The Evaluation Device Type 656 B is applied for the current-signal detection and evaluation of vibration controls in two-wire technology. At the Evaluation Device switching-threshold and delay can be set. If the signal is falling below the switching-threshold and the delay has expired, this will be signalled by means of LED and relay. Cable break and missing voltage supply will also be signalled. At a later stage this signals can be used for the generation of an alarm.

Intended Use Type 656 B

The Evaluation Device Type 656 B exclusively serves for the current-signal detection and evaluation of vibration sensors. The operation is valid exclusively within the specifications mentioned in this manual.

Main areas of application: Vibration measurement on conveyor and sieving equipment, drying and cooling systems and similar oscillating mechanical plants and equipment, were the vibration must not be lower than a specific value.

Electrical Data Type A / B

Input signal:	Current-signal 4...20 mA
Output signal:	- OK-Relay-Contact - Alarm-Relay-Contact - Voltage supply for sensor: 24 V DC \pm 10%
Switching threshold:	between 4...20 mA, infinitely adjustable, hysteresis 2%
Delay:	between 0...30 s, infinitely adjustable
Relay-contacts:	Changer Switching voltage max. 250 V AC Switching voltage max. 60 W, 125 VA
Voltage supply:	24 V DC \pm 10%
Power consumption:	ca. 1 VA
Working temperature range:	0°C...+70°C

Mechanical Data Type A / B

Casing:	Plastic, grey 12-pin DIN track-casing
Weight:	app. 200 g
Protection grade:	IP 40

Housing Dimensions Type A / B

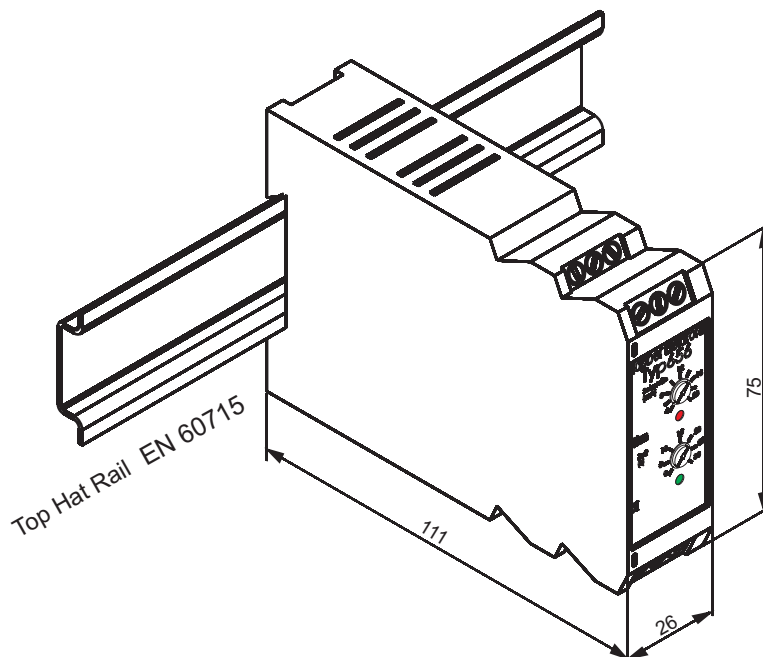

All measures in mm.

Connections and User Interface Type 656 A / B

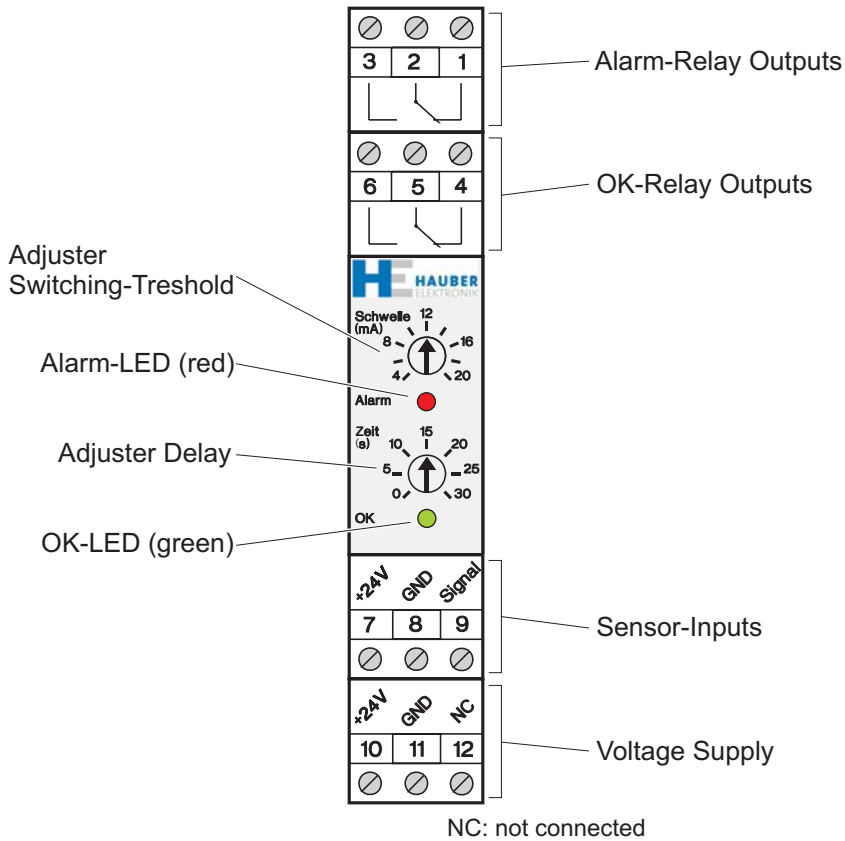

Displayed Relays Switching-Status: No Power Supply (LEDs off).

Connection Example Type 656 A / B

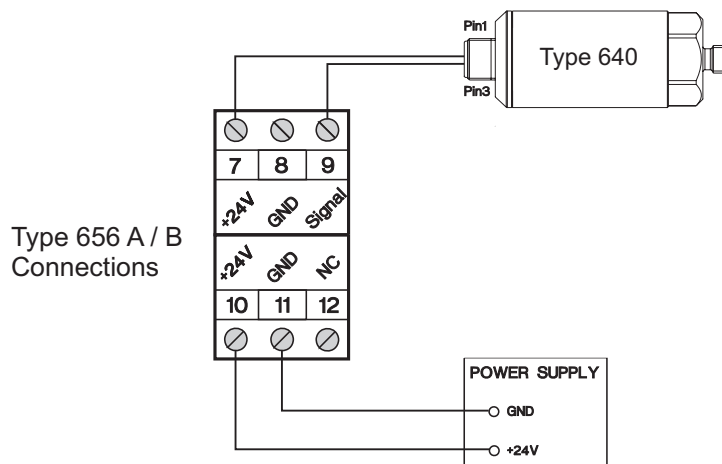

Type 656 A / B connected to Vibration Control Type 640 and Power Supply

Alarm Conditions Type 656 A

As long as the sensor signal (contact 9) is below the switching-threshold, the red Alarm-LED is OFF and the Alarm-Relay-Contacts 2 and 3 are closed.

If the signal is exceeding the switching-threshold and the delay is running, the red Alarm-LED is BLINKING and the Alarm-Relay-Contacts 2 and 3 are closed.

If the signal is exceeding the switching-threshold and the delay has expired, the red Alarm-LED is ON and the Alarm-Relay-Contacts 2 and 1 are closing.

Sensor Signal	Alarm-Relay	Alarm-LED (red)
Below threshold	K2,3 ^{1.)}	OFF
Threshold exceeded, delay running	K2,3	BLINKING
Threshold exceeded, delay expired	K1,2	ON
Below threshold again	K2,3	OFF

1.) K2,3 means: Contacts 2 and 3 are closed.

Alarm Conditions Type 656 B

As long as the sensor signal (contact 9) is above the switching-threshold, the red Alarm-LED is OFF and the Alarm-Relay-Contacts 2 and 3 are closed.

If the signal is lower than the switching-threshold and the delay is running, the red Alarm-LED is BLINKING and the Alarm-Relay-Contacts 2 and 3 are closed.

If the signal is lower than the switching-threshold and the delay has expired, the red Alarm-LED is ON and the Alarm-Relay-Contacts 2 and 1 are closing.

Sensor Signal	Alarm-Relay	Alarm-LED (red)
Above threshold	K2,3	OFF
Lower than threshold, delay running	K2,3	BLINKING
Lower than threshold, delay expired	K1,2	ON
Above threshold again	K2,3	OFF

Device Conditions Type 656 A / B

In OK-Condition the green OK-LED is ON and the OK-Relay-Contacts 5 and 6 are closed.
In case of cable break of the connected sensor, the OK-LED is BLINKING and OK-Relay-Contacts 5 and 4 are closing.

In case of missing power supply the OK-LED is OFF and the OK-Relay-Contacts 5 and 4 are closed.

Device conditions	OK-Relais	OK-LED (grün)
OK-Condition ^{2.)}	K5,6	ON
Cable break	K5,4	BLINKING
No Power supply	K5,4	OFF

2.) OK-Condition means: Power supply available and no cable break.