

Vibration Sensor Type 640



Standard



Zone-1-21 



Zone-2-22 

Instruction Manual

English

Instruction Manual

Vibration Sensor Type 640

Standard
Zone-1-21
Zone-2-22

Edition: 12.04.10

Attention!

Before Start-Up Procedure the Instruction Manual must be read and understood!

Should any question arise, please contact:

HAUBER-Elektronik GmbH
Fabrikstraße 6
D-72622 Nürtingen
Germany
Phone: +49 (0) 7022 / 62393
Fax: +49 (0) 7022 / 64143
info@hauber-elektronik.de
www.hauber-elektronik.de

Content

1 Safety Informations.....	4
2 Instruction Manual Scope	5
3 The Vibration Sensor Type 640.....	5
Standard, Zone-1-21, Zone-2-22	
4 Intended Use	5
5 Documents and Certificates	5
6 Responsibility for the Safe Operation / Disclaimer	5
7 Application Fields	6
8 Delivery Contents	6
9 Electrical Data	7
10 Mechanical Data.....	8
11 Connections.....	9
12 Mounting and Demounting	10
12.1 Fastening at the Mounting Surface	10
12.2 Zone-2-22 - Fastening Safety Clip / Protective Cover	11
13 Installation and Start-Up	12
14 Maintenance and Repairs.....	12

1 Safety Instructions

In General

The safety instructions serve the protection of persons and things from damage and danger that arise from not intended use and further misuse of products especially in explosion endangered areas. Therefore read the instruction manual carefully, before working with or starting-up the product. To the operating personnel the instruction manual has to be accessible anytime.

Before the starting-up or miscellaneous works with the product please check, whether all the documents are available completely. If not all the documents are committed completely or further copies are required, they can be obtained in different languages.

Our product is designed to the latest state of the art. Nevertheless there are a number of residual risks. This means that each person in the operators firm, concerned with mounting and dismounting, installation, start-up, operating or maintenance of the product, has to have read and understood the instruction manual.

This means furthermore that each person in the operators firm, concerned with mounting and dismounting, installation, start-up, operating or maintenance of the product, has to be an authorized expert, familiar with the safety instructions for handling electrical components. For handling ATEX-certified products within explosion endangered surroundings the expert in addition has to be familiar with the safety instructions relevant there.

Used Symbols



This symbol indicates an explosion hazard.



This symbol indicates a risk from electrical current.



This symbol indicates a (non-safety relevant) information.

2 Instruction Manual Scope

The present instruction manual of the Vibration Sensor Type 640 is applicable for the following variants: Standard, Zone-1-21 and Zone-2-22.

The functionality of the variants is identical. In addition the variants have certifications and labellings, that allow operation in explosion endangered areas. (see chap. 7, Operation Areas)

3 The Vibration Sensor Type 640

The Vibration Sensor Type 640 ist applied for measurement of machines absolute bearing vibration, referring to DIN ISO 10816. It works to Two-Wire-System. The Measurement parameter is the root mean square (rms) of the vibration velocity, the unit is mm/s. The Sensor contains an electronic device that delivers an interference-free 4...20 mA Output-Signal, proportional to the Sensors measuring-range.

4 Intended Use

The Type 640 exclusively serves for the measurement of mechanical vibrations of machines and mechanical facilities. The operation is valid exclusively within the specifications mentioned in this manual. **Main areas of application:** Industrial fans, ventilators, blowers, electric motors, pumps, centrifuges, seperators, generators, turbines, and similar, oscillatory mechanical equipment.

5 Documents and Certificates

Following Type 640 Documents und Certificates can be consulted on www.hauber-elektronik.de:

- EC-Conformity-Declaration
- EC-Type-Examination-Certificate ATEX-Zone 1 und 21, no.: PTB 06 ATEX 1072
- Statement-of-Conformity ATEX-Zone 2 und 22, no.: LU 06 ATEX 0018X



6 Responsibility for the Safe Operation / Disclaimer

The correct layout of the electrical plant under conditions of explosion protection, as well as the correct switch on procedure, is the sole responsibility of the user of the plant.

The current valid explosion protection rules and security regulations must be adhered to and must be under given circumstances checked by a competent person. Should the plant on the order of the user be erected by a subcontractor, the plant must only be switched on after the subcontractor has submitted an installation certificate as prove of the correct nature of the installation, according to the relevant valid regulations.

The primary switch on of explosion protected plants or part of plants, as well as the subsequent switch on after major adjustments or maintenance work, must be reported to the relevant authorities by the owner.

7 Application Fields

Variante	Application Fields	Labelling
Standard	None explosion endangered areas	none
Zone-1-21	Explosion endangered areas Zone 1 and 21	 II 2G Ex d IIC T4 II 2D Ex tD A21 IP65 T120 °C
Zone-2-22	Explosion endangered areas Zone 2 and 22	 II 3G Ex nC II T4 II 3D Ex tD A 22 IP55 T125 °C

8 Delivery Contents

Variant	Delivery Contents
Standard	<ul style="list-style-type: none"> • Vibration Sensor Type 640 • Instruction Manual
Zone-1-21	<ul style="list-style-type: none"> • Vibration Sensor Type 640 • Instruction Manual
Zone-2-22	<ul style="list-style-type: none"> • Vibration Sensor Type 640 • Instruction Manual • Safety Clip • Protective Cover for M12-Plug
Available Supplies	<ul style="list-style-type: none"> • Evaluation Equipment Type 656 • Evaluation Equipment Type 652 • Various Adapters, e.g. M8 -> M10 • Allocable Mating Connector, M12, 8-pole • Connection Cable, M12-Socket, 4-pole, 0,34 mm², L= 2 m, 5 m oder 10 m or on request • Magnet Foot

9 Electrical Data



Before Starting-Up the Sensor, the mains must be secured with a microfuse (time delay, 32 mA, breaking capacity C)!

Measuring Range:

0... 8 mm/s
 0... 16 mm/s
 0... 32 mm/s
 0... 64 mm/s
 0... 128 mm/s
 0... 256 mm/s
 0... 512 mm/s
 0... 1000 mm/s



Each Sensor has **one** of the listed measuring ranges. Further ones on request.

Measuring accuracy:

± 5%

Frequency range:

10 Hz...1000 Hz

Output signals:

4...20 mA (Proportional to the Measuring Range)

Voltage supply:

24V DC ±10%

Power input (max.):

25 mA

Shock (max.):

1000 g

Burden/Load:

500 Ω

Fusing:

Microfuse (Time delay, 32 mA, breaking capacity C)

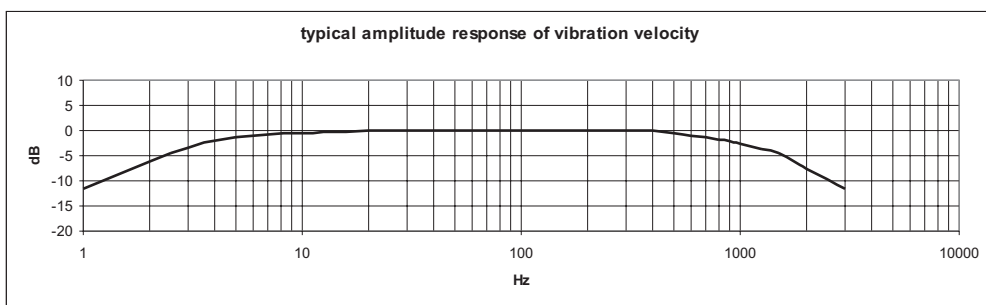

Fig. 1: Frequency Range 10 Hz...1000 Hz

Valid Operating Temperature Ranges of all Variants

	Standard	Zone-1-21	Zone-2-22
Ambient Temperature	-20 °C...+60 °C	-20 °C...+60 °C	-20 °C...+60 °C
Measuring Head-Temperatur (at the Fastening)	-40 °C...+85 °C optional: -40 °C...+125 °C	-20 °C...+100 °C	-40 °C...+100 °C

10 Mechanical Data

Housing Material:

M12-connector / cable gland:

Fastening:

Securing:

Weight:

Protection Style:

Stainless Steel V2A; material no: 1.4305

CuZn (brass), nickel plated

Wrench Size: 24 (hexagon), M8 x 8

The Sensor must be earthed via the M8 fastening (see chapt.12).

ca. 150 g

IP 67

Housing Dimensions and Direction of Measurement

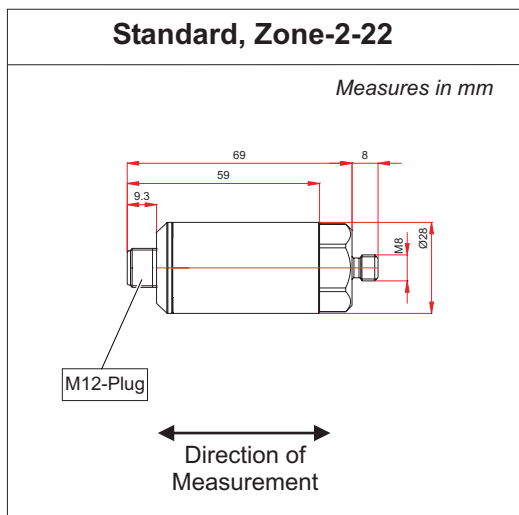

Fig. 2: Housing Dimensions and Direction of Measurement: Standard, Zone-2-22.

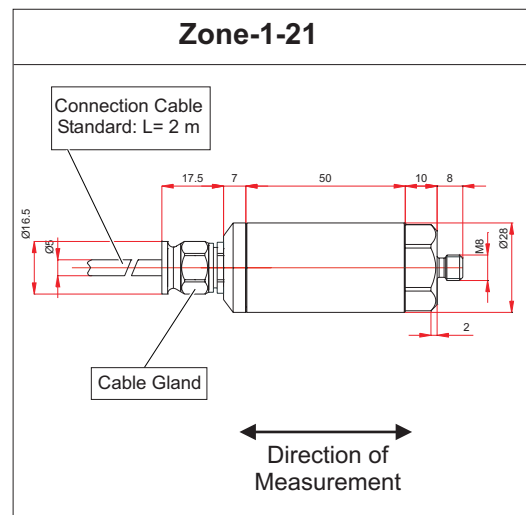
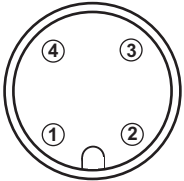
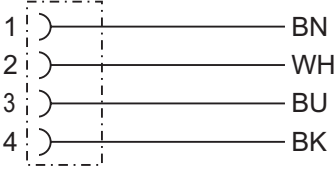
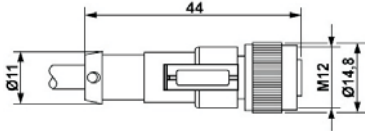

Fig. 3: Housing Dimensions and Direction of Measurement: Zone1-21



Note: Direction of Measurement = Direction of Fastening

11 Connections

Standard, Zone-2-22	Zone-1-21
<p style="text-align: center;">M12-Plug</p>  <p><i>Fig. 4: M12-Plug, 4-pole. Pin allocation see Connection Plan.</i></p>	<p style="text-align: center;">Connection Cable</p>  <p><i>Fig. 5: PUR-sheathed-cable, 4-pole, 0,25 mm², Standard: L= 2 m. Pin allocation see Connection Plan.</i></p>
<p style="text-align: center;">Connection Cable Socket (Supplies)</p>  <p><i>Fig. 6: Connection cable socket M12, 4-pole, 0,34 mm². Pin allocation see Connection Plan.</i></p>	

Connection Plan for all 3 Variants

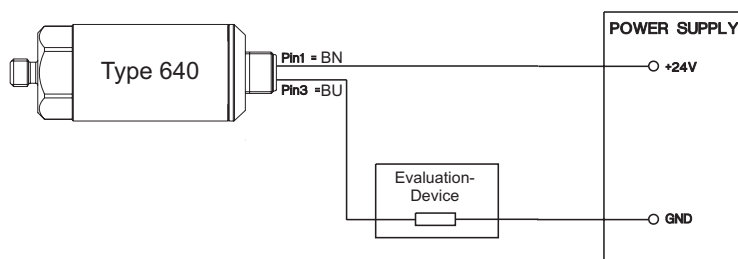

To avoid capacitive Coupling Interferences, the Pins 2 and 4 have to stay **open** resp. **free!**

12 Mounting and Dismounting

Mounting and Dismounting works at and with the Sensor may only be executed by an authorized expert, familiar with the safety instructions for handling electrical components. For handling ATEX-certified Sensors within explosion endangered surroundings the expert in addition has to be familiar with the safety instructions relevant there.



Before mounting and dismounting works the Sensor has to be separated from the mains! Separated plug and socket devices always have to be disconnected from the mains! Otherwise danger of explosion because of sparking, when operating ATEX-certified Sensors in explosion endangered areas!



The Sensor housing must be earthed via ist fastening - i. e. via machine earth or via a separate earth wire (PE)!

12.1 Fastening at the Mounting Surface

Preconditions

- Mounting surface clean and flat, i.e. free from paint, rust, etc.
- Threaded hole at the Mounting surface:
Depth: 10 mm
Thread: M8

Tools and Materials

- Allen wrench, SW24

Working Steps

- Tighten Sensor **friction-locked** into the threaded hole of the mounting surface.



To obtain exact measuring values, the Sensor has to be tighten **friction-locked** at the mounting surface!

Avoid Auxiliary Constructions! If unavoidable, implement it as stiff as possible!

12.2 Zone-2-22 - Fastening Safety Clip / Protective Cover



The operation of variant Zone-2-22 is not permitted without the Safety Clip, to avoid accidentally disconnecting the plug-in connection! Otherwise danger of explosion because of sparking, when operating in explosion endangered areas!

Fastening Safety Clip

1. Plug in the connection cable socket into the M12-plug completely.
(Pay attention to the code cam!).
2. Tighten firmly the lock-nut of the connection cable socket by hand.
3. Fasten the safety clip against accidental disconnection of the plug connection:
 1. Put both shell halves of the safety clip around the plug connection.
 2. Press together by hand both shell halves of the safety clip until the catch lock snaps in.
 3. Put the arrow connected to one shell half around the cable, then stick it through the eye on the other end, so that the notice sign is readable alongside the cable.

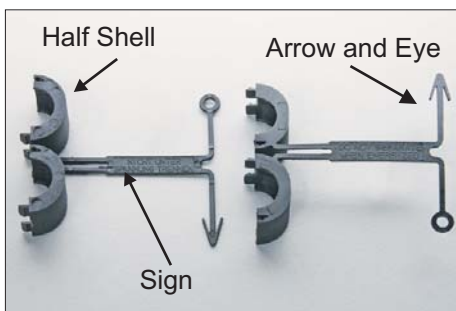

Fig. 7: Safety Clip



Fig. 8: Fastened Safety Clip

Fastening Protective Cover

After disconnecting the plug connection the protective cover has to be mounted!

Disassemble the safety clip and mount the protective cover:

1. Disconnect mains / electric circuit.
2. Separate both shell halves of the fuse clip with a screw driver.
3. Fasten protective cover and skrew it tightly onto the sensor plug.



Fig. 9: Protective Cover



Fig. 10: Fastened Protective Cover

13 Installation and Start-Up

Installing and starting-up the Sensor may only be executed by an authorized expert, familiar with the safety instructions for handling electrical components. For handling ATEX-certified Sensors within explosion endangered surroundings the expert in addition has to be familiar with the safety instructions relevant there.



Prior to starting-up the Sensor, the mains must be secured with a microfuse (time delay, 32 mA, breaking capacity C)!



The connection cable and possible extension cables must be protected against electrical influences and mechanical damages. Here local regulations and commissions absolutely have to be considered.

14 Maintenance and Repair

Repairing the Sensor may only be executed by an authorized expert, familiar with the safety instructions for handling electrical components. For handling ATEX-certified Sensors within explosion endangered surroundings the expert in addition has to be familiar with the safety instructions relevant there.



Prior to repair and cleaning works the Sensor has to be separated from the mains! Separated plug and socket devices always have to stay disconnected from the mains! Otherwise danger of explosion because of sparking, when operating ATEX-certified Sensors in explosion endangered areas!



Defective connection cables immediately have to be replaced! Otherwise danger of explosion because of sparking, when operating ATEX-certified Sensors in explosion endangered areas!

A defective control has to be changed completely!



Note: The Type 640 and its variants are maintenance free!

Errortable

Error	Cause	Activity
No Measured Value (4-20 mA)	No Power Supply	Check Power Supply and/or Connection Cable
	Connection Cable interrupted	Replace Connection Cable
	Fuse defective	Replace Fuse
	Connection wrong Polarity	Provide correct Polarity
	Sensor defective	Replace Sensor
Measured Value wrong	Sensor mounting not friction-locked	Mount Sensor friction-locked
	Sensor mounting at wrong position	Mount Sensor at correct position